

OWCT16M-xxxT-xxx Standard Measuring Current Transformer Split Type 16MM

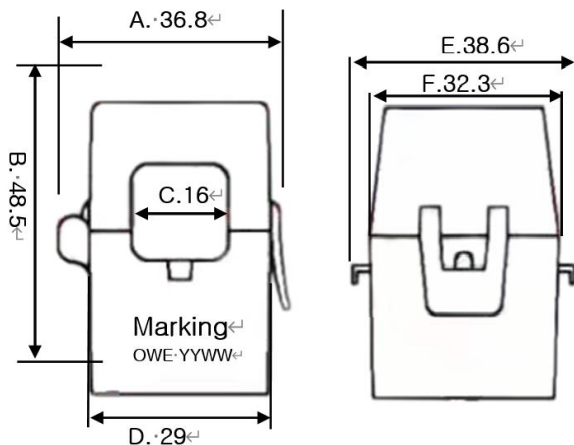

Audio Jack Connector Dimension:

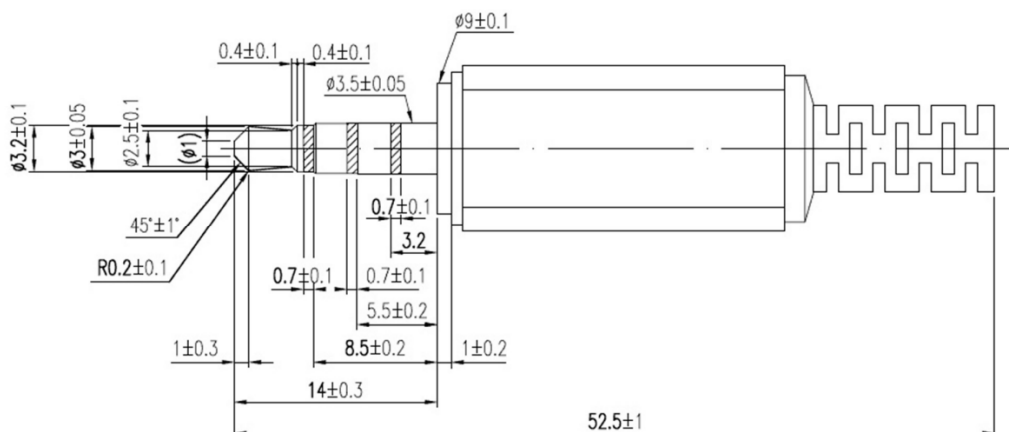

GENERAL INFORMATION

- Operation Temp: -30°C to +70°C
- Humidity: ≤ 95%
- Altitude ≤ 2000m
- Storage condition: 0-40°C and ≤70% (In original packaging)
- Ferrite Split Core current Transformer

FEATURES

- Accuracy Class: 0.5
- Operating Frequency: 50Hz to 200KHz
- Input Voltage: 230V 1phase / 400V 3phase
- Input Current Range: 1-150A without loading
- Power-Frequency withstand voltage: 2.5KV 60"
- Insulation Resistance : ≥ 100Mohm with DC 500V
- Voltage Level: 660/720V
- Lifetime ≥ 10years
- Flexible installation

APPLICATIONS

- Smart Metering
- Mainly for isolating, collecting, and measuring AC Current signals in the primary main circuit.
- Analog to Digital Circuit
- Sensing Overload Current
- Ground fault detection

CERTIFICATION

- RoHS Approval: Complaint 2011/65/EU & 2015/863
- REACH Approval: IEC1907/2006
- Halogen Free: IEC 61249-2-21
- IEC62869-2 : Suitable
- UL94 V0: Suitable

NOTICE

- This electronic component was designed and manufactured for use in general electronic equipment.
- Don't drop test or impact on the single component.
- Violation of the technical product specifications such as exceeding the nominal rated current may damage the product.
- Current transformers must not be used in an open circuit, nor can they be connected to fuses

➤ **DIMENSIONS OF OWCT16M-xxxT-xxx Split Core Current Transformer-Ferrite material**

OW Series	A(mm)	B(mm)	C(mm)	D(mm)	E(mm)	F(mm)	G(mm) Cable Lenth
OWCT16M-xxxT-xxx	36.8+/-0.3	48.5+/-0.5	16+/-0.5	29+/-0.3	38.6+/-0.5	32.3+/-0.3	500 Min.

Note: OWCT 16 M - xxxT-xxxx

- Rated Current on primary
- Current Transformer winding Turns number: 1KT = 1000ts, 1.5KT=1500ts
- Current Transformer Core material: F = Ferrite core, N= Nano-core
- Primary Cable wire size : 16 = OD 16mm, 25 = OD 25MM

➤ **Electrical Characteristics of OWCT16M-xxxT-xxx Split Core Current Transformer-Ferrite material**

No.	Item	Unit	Product Models				
			OWCT16M-1KT-100A	OWCT16M-2KT-100A	OWCT16M-3KT-100A	OWCT16M-4KT-100A	OWCT16M-5KT-100A
1	Turns Ratio(Kr)	/	1000:1	2000:1	3000:1	4000:1	5000:1
2	Rated Input Current	A(ac)	100	100	100	100	100
3	Frequency	HZ	50/60	50/60	50/60	50/60	50/60
4	Rated Output Current	mA (ac)	100	50	50	25	20
5	Rated Accuracy Erro	± %	0.5	0.5	0.5	0.5	0.5
6	Phase rated Erro	± Minutes	60(RL=0)	45(RL=0)	45(RL=0)	45(RL=0)	45(RL=0)
7	Linearity	± %	0.3	0.3	0.3	0.3	0.3
8	Rated sampling resistance	Ω	20	100	75	300	400
9	Rated sampling voltage	V(ac)	2	5	3.75	7.5	8
10	Measuring Input Current range	A(ac)	0-100 (RL≤20Ω)	0-150 (RL≤100Ω)	0-150 (RL≤75Ω)	0-150 (RL≤50Ω)	0-150 (RL≤50Ω)
11	Max. Input Current	A(ac)	120 (RL≤10Ω)	200 (RL≤10Ω)	190 (RL≤10Ω)	180 (RL≤10Ω)	160 (RL≤10Ω)
12	Inner Resistor	Ω	41±5	125±15	293±30	565±50	860±80
13	Power Freq. Voltage	V	2500V,60"	2500V,60"	2500V,60"	2500V,60"	2500V,60"
14	Insulation Resistance	MΩ Min. 500Vac	500	500	500	500	500

Note: There is Diode inside to avoid open, and good for operation safety.



➤ Schematic of OWCT16M-xxxT-xxx Split Core Current Transformer-Ferrite material

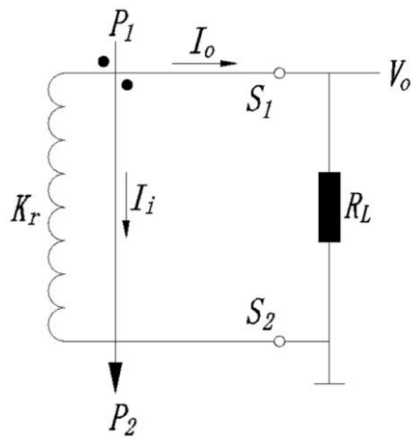

Description on Schematic:

Calculation formula :

$$V_o = I_o \times R_L = \frac{I_i}{K_r} \times R_L$$

1	K_r	Rated Ratio
2	I_i	Input Current
3	I_o	Output Current
4	R_L	Sampling Resistor
5	V_o	Output Voltage

➤ Characteristics Chart of OWCT16M-xxxT-xxx Split Core Current Transformer-Ferrite material

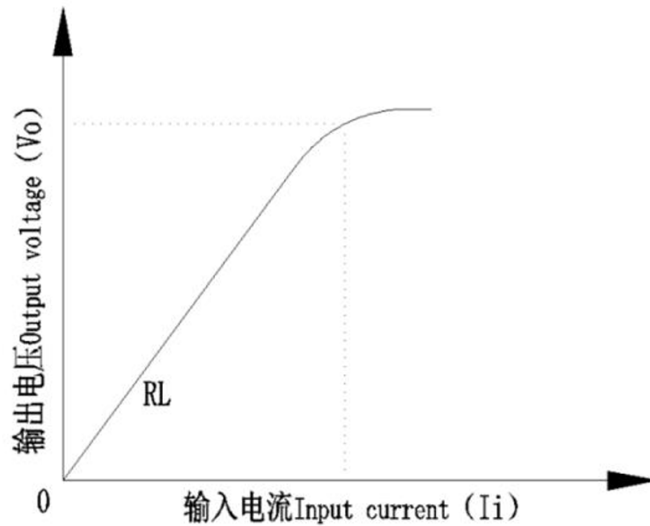

➤ **Packaging Detail of OWCT16M-xxxT-xxx Split Core Current Transformer-Ferrite material**

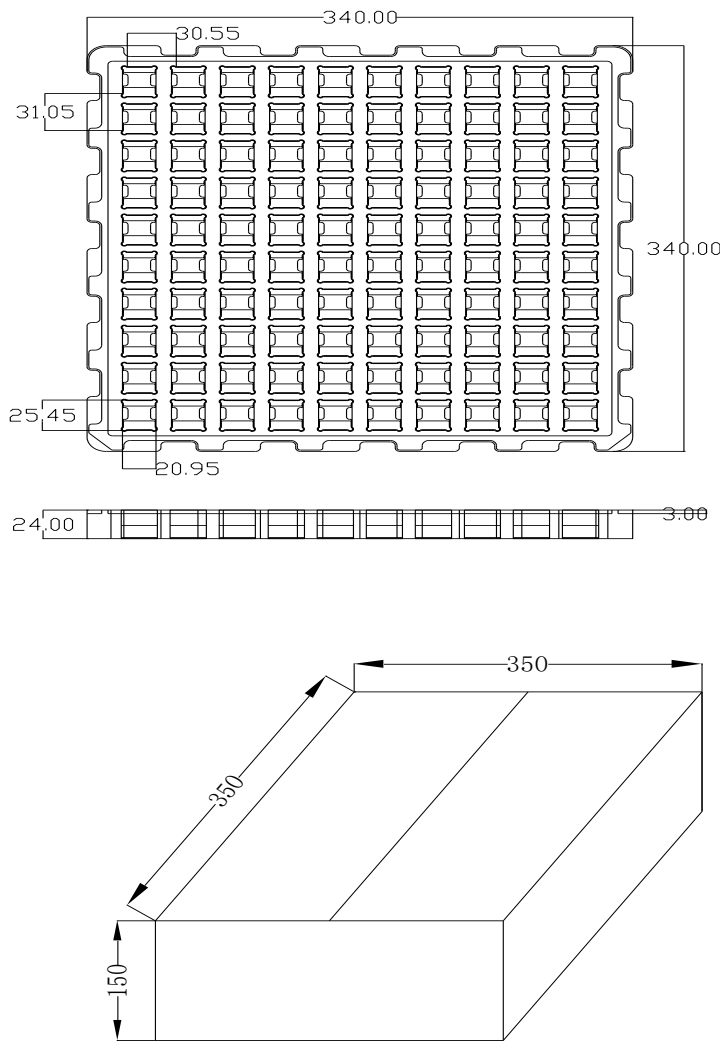

Item	Description
Bulk Packing	Paper box
Tray material	Degradable Plastic
Box Size	350x350x150
Tray size	340x340x18
Qty /Full tray	TBDpcs
Qty/Full Box	TBDpcs
Unit Weight	80.6g
Gross Weight	10Kg

Notice:

- A storage of OW products for longer than 12months is not recommended, the terminals may suffer degradation during storing, then the resulting in bad soldering performance. Customer need to be pre-evaluated the solderability before using over 12months inventory.
- Do not expose the component to direct sunlight, or to high humidity ambient.
- The storage conditions in the original packaging are defined according to EN61670-2, 12months shelf life Max. is in original packaging.
- It has to be clearly pointed out that the possibility of a malfunction of electronic components or failure before the end of the usual lifetime cannot be completely eliminated in the current state of the art, even if the products are operated within the range of the specifications.
- The temperature rise of the component must be taken into consideration. The operating temperature is comprised of ambient temperature and temperature rise of the components. The operating temperature of the component shall not exceed the maximum temperature specified.
- Please handle it carefully because it is a fragile component. Please re-test and evaluate it again if the component is dropped to the floor.



➤ **Measurement Current Transformer instruction:**

● **Current Transformer core material comparison.**

CT Type	Core material	Sturation Voltage	Amplitude Error	Phase Error	Freq.	Losses	Tempe. a variance	Cost	Description
General Purpose	Silicon-Steel	High	1%	< 1°	50Hz-1KHz	Highest	High	\$	Low cost, non-revenue sensing applications. Use for high voltage output design: eg. dive LEDs, Switches, Relays, etc. Low accuracy sensing: eg. motor controls, indications of current.
Revenue Grade	Nicke-Steel	Low	0.2%	< 20'	50Hz-1KHz	Lowest	Very Low	\$\$\$	Power metering applications, temperature independent sensing. High accuracy applications: eg. energy management and load sensing; Low current sensing applications: eg. Ground fault and leakage detechtors
High Frequency	Ferrite	Medium	1%	< 1°	Up to 2KHz	Highest	High	\$	SMPS Power supply current sensing, low cost and high frequency indicators. High frequency power system and motor drives
DC Immune	Special Complex assemble core	Medium	0.5%	< 1°	50Hz-1KHz	Medium	Medium	\$\$\$	Special applications which have DC component in power signal. Special current transformer used to prevenet theft of power from grid utilizing half-wave illegal connections
Amorphous & Nano	Special	High	0.5%	< 100'	Up to 2KHz	Small	Low	\$\$	Modern material. High Frequency, good satturation voltage, and high initial permeability makes for good another optional for ferrites and silicone steel, drop in replacement to increase accuracy over all materials except Nickek-steel.

- A current transformer is an instrument transformer in which the secondary current, in normal conditions of use, is substantially proportional to the primary current and differs in phase from it by an angle which is approximately zero. It is designed by international standard IEC61869-2:2012

● **Accuracy class:**

it is a designation assigned to a current transformer where the errors remain within specified limits under prescribed conditions of use.

For all classes, the burden shall have a power-factor of 0,8 lagging except that, when the burden is less than 5 VA, a power-factor of 1,0 shall be used, with a minimum value of 1 VA.

-- For classes 0.1 – 0.2 – 0.5 and 1.0 the ratio error and phase displacement at rated frequency shall not exceed the values given in Table 201 where the burden can assume any value from 25 % to 100 % of the rated output

Table 201 – Limits of ratio error and phase displacement for measuring current transformers (classes 0,1 to 1)

Accuracy class	Ratio error				Phase displacement							
	± %				± Minutes				± Centiradians			
	at current (% of rated)				at current (% of rated)				at current (% of rated)			
	5	20	100	120	5	20	100	120	5	20	100	120
0,1	0,4	0,2	0,1	0,1	15	8	5	5	0,45	0,24	0,15	0,15
0,2	0,75	0,35	0,2	0,2	30	15	10	10	0,9	0,45	0,3	0,3
0,5	1,5	0,75	0,5	0,5	90	45	30	30	2,7	1,35	0,9	0,9
1	3,0	1,5	1,0	1,0	180	90	60	60	5,4	2,7	1,8	1,8

-- For classes 0.2S and 0.5S the ratio error and phase displacement at the rated frequency shall not exceed the values given in Table 202 where the burden can assume any value from 25 % and 100 % of the rated output.

Table 202 – Limits of ratio error and phase displacement for measuring current transformers (classes 0,2S and 0,5S)

Accuracy class	Ratio error					Phase displacement									
	± %					± Minutes				± Centiradians					
	at current (% of rated)					at current (% of rated)				at current (% of rated)					
	1	5	20	100	120	1	5	20	100	120	1	5	20	100	120
0,2 S	0,75	0,35	0,2	0,2	0,2	30	15	10	10	10	0,9	0,45	0,3	0,3	0,3
0,5 S	1,5	0,75	0,5	0,5	0,5	90	45	30	30	30	2,7	1,35	0,9	0,9	0,9

-- For class 3 and class 5, the ratio error at rated frequency shall not exceed the values given in Table



203 where the burden can assume any value from 50 % to 100 % of the rated output. There are no specified limits of phase displacement for class 3 and class 5.

Table 203 – Limits of ratio error for measuring current transformers (classes 3 and 5)

Class	Ratio error	
	± %	
	at current (% of rated)	
	50	120
3	3	3
5	5	5

● **Phase Displacement**

Phase Displacement is the difference in phase between the primary and secondary current vectors: θ =phase angle error being zero for ideal current transformer.

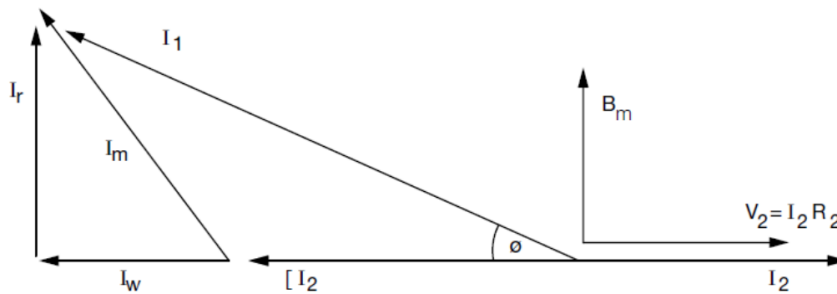

Symbol	Description
I_1	Primary Current
I_2	Secondary Current
N	Secondary Turns
I_m	Excitation Current
I_r	Reactive component of I_m
I_w	Watts Loss components of I_m
V	Secondary Voltage
R_2	Burden resistance
θ	Phase angle Error
e	Current Error

Note: 1) The Primary current I_1 difference from the secondary I_2 magnitude and phase angle
The angle error θ is $\text{Sin}^{-1} I_r/I_1$ and magnitude of $I_1 = \sqrt{\{ (I_2N)^2 + I_w^2 \} + I_r^2}$

$\theta = I_r/I_1$ radians and $I_1 = I_2N^2 + I_w$

2) Ratio error can be corrected by amendment to the turns ratio, i.e. \pm secondary turns.

3) Phase angle cannot be turns corrected since it is a function of the reactive component of the excitation characteristics of the core

● **Turns Ratio**

The turns ratio of a current transformer can be altered by using multiple turns. The example below shows how a 300/5 A CT can be used as a 100/5 A CT by using three primary loops to reduce the turns ratio from 60:1 to 20:1. This enables a higher rated current transformer to be used to measure lower currents.

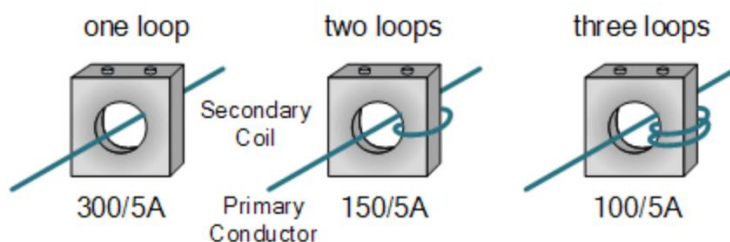

While it is desirable to have zero phase shift between primary and secondary current, for 5 A measuring CT's it is not so important since ammeters only show the magnitude of the current.

● **Metering Current Transformer**



--A metering current transformer is designed to measure current continuously and work accurately within the rated current range. Current error and phase displacement limits are determined by the accuracy class. Accuracy classes are: 0.1, 0.2, 0.5 and 1.0

--In watt meters, energy meters, and power factor meters, phase shift produces errors. However, the introduction of electronic power and energy meters has allowed current phase error to be calibrated out.

--When current exceeds the rating, the metering CT will saturate thereby limiting the current level within the instrument. Core materials for this type of CT typically have low saturation level, such as nanocrystalline.

● **Protection Current Transformer**

--A protection current transformer is designed to operate well into the overcurrent range. This enables the protective relays to measure fault currents accurately, even in very high current conditions. The secondary current is used to operate a protective relay which can isolate part of the power circuit experiencing a fault condition.

-- Core material for this type of CT has high saturation level and is normally made from silicon steel.

--The knee point voltage of a current transformer is defined as the voltage at which a 10% increase in voltage of the CT secondary results in a 50% increase in secondary current. This also means that an increase in current of 50% will lead to an increase in voltage of just 10%.

--The knee point voltage is important for protection class CTs, i.e. where the CT is used for protection purposes.

--Standard classes for protection CT's are 5P 10 and 10P 10, where P is the designation for protection. The number before P indicates the composite error percentage. The number after the letter indicates the factor of primary current up to which composite error will be achieved, i.e. 10x the rated primary current in 5P 10 and 10P 10.

-- Protection devices will normally specify the classification for the protection CT intended to operate the protection device concerned.

Table 205 – Error limits for protective current transformers class P and PR

Accuracy class	Ratio error at rated primary current ± %	Phase displacement at rated primary current		Composite error at rated accuracy limit primary current %
		± Minutes	± Centiradians	
5P and 5PR	1	60	1,8	5
10P and 10PR	3	–	–	10

● **Simple Current Transformer**

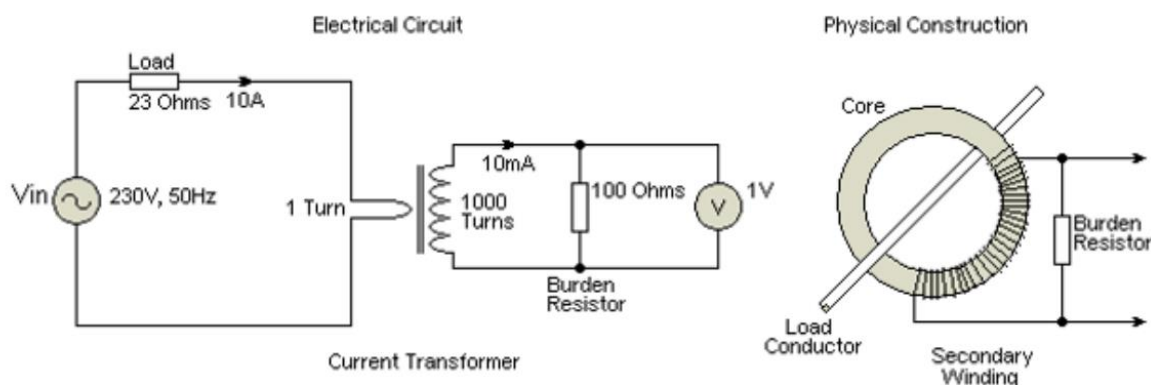

Simple CT Circuit

$$I_p = 10$$

$$I_s = 10/1000 = 10 \text{ mA}$$

$$V_b = 10 \text{ mA} \times 100 = 1 \text{ V}$$

● **Influence of Altitude On temperature-rise**

--If an instrument transformer is specified for service at an altitude in excess of 1 000 m and tested at an altitude below 1 000 m, the limits of temperature rise ΔT given in Table 5 shall be reduced by the following amounts for each 100 m that the altitude at the operating site exceeds 1 000 m (see below):



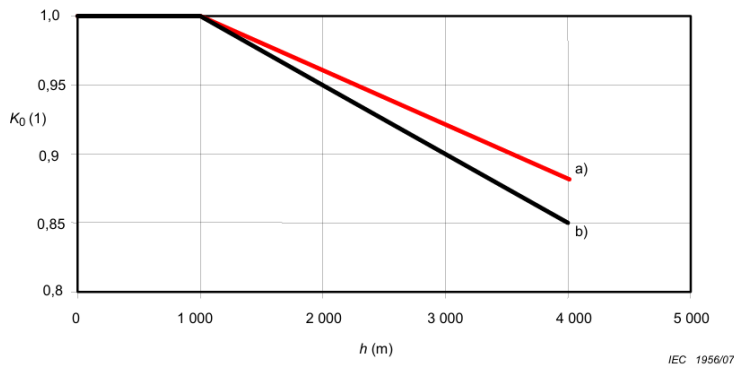

Figure 1 – Altitude correction factor for the temperature rise

The altitude correction factor for the temperature rise $K_o = \frac{\Delta T_h}{\Delta T_{ho}}$ with

- ΔT_h temperature rise at altitude $h > 1\,000$ m and
- ΔT_{ho} limits of temperature rise ΔT specified in Table 4 at altitudes $h_o \leq 1\,000$ m.

➤ Caution and Notice

- Above mentioned information should serve as recommendation only. Other parameters may also affect soldering results, so these profiles do not guarantee absolute success.
- Soldering profile should be determined by the manufacturer of the solder paste, providing there is no contradiction with the recommendations in this document.
- Strong forces which may affect the coplanarity of the components' electrical connection with the PCB (i.e. pins), can damage the part.
- Washing during the production to clean the customer application may damage or change the characteristics of the wire insulation, marking or plating. Washing may have a negative effect on the long-term functionality of the product. Customer need to be own evaluation risk.
- We do not recommend using brush PCBA during the cleaning process after soldering.
- If the product is potted in the customer applications, the potting material maybe shrink or expand after hardening, and lead to the part's electrical characteristics change or core crack, customer need to own evaluation the potting risk.
- A stroage of OW products for longer than 12months is not recommended, the terminals may suffer degradation during storaging, then the resulting in bad soldering performacne. Customer need to be pre-evaluated the solderability before using over 12months inventory.
- Do not expose the compoent to direct sunlight, or to high humidity ambinet.
- The stroage conditions is in the original packaging are defined according to EN61670-2, 12months shelf life Max. is in original packaging.
- It has to be clearly pointed out that the possibility of a malfunction of electronic components or failure before the end of the usual lifetime .cannot be completely eliminated in the current state of the art, even if the products are operated within the range of the specifications.
- The temperature rise of the component must be taken into consideration. The operating temperature is comprised of ambient temperature and temperature rise of the components .The operating temperature of the component shall not exceed the maximum temperature specified.
- Please hand it carefully because it is fragile component. Please re-test and evaluate it again if the component dropped to floor.

