

Schematics

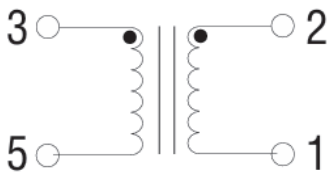

Land Pattern

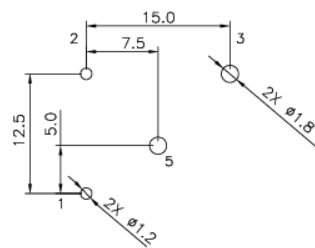

OWCSTxxxT-Bxxx Current Sensor Transformer

Monitoring & Measuring AC Current 25A Primary Built-In Type

GENERAL INFORMATION

- Operation Temp: -40°C to +125°C
- Humidity: ≤ 95%
- Altitude ≤ 2000m
- Storage condition: 0-40°C and ≤70% (In original packaging)
- current Transformer

FEATURES

- Frequency range: 1KHz to 500KHz
- Primary Current range: 0 to 25A
- Dielectric withstanding Voltage : 4000Vac
- Optimum performance over designated current and frequency range
- Full encapsulated constructure
- Low cost.

APPLICATIONS

- High resolution sonar current
- Isolated current feedback signal in switch mode power supplies
- Monitor current load/ overload
- Lighting
- Switch controls Ultra-sound current
- Isolated bi-directional current sensor with full wave bridge rectifier

CERTIFICATION

- RoHS Approval: Complaint 2011/65/EU & 2015/863
- REACH Approval: IEC1907/2006
- UL94 V0: Suitable

NOTICE

- Current Sensors are for monitoring or measuring AC current. They serve as feedback elements between the output and pulse control circuitry providing accurate regulation of switch mode power supplies
- This electronic component was designed and manufactured for use in general electronic equipment.
- Don't drop test or impact on the single component.
- Violation of the technical product specifications such as exceeding the nominal rated current may damage the product.
- Current transformers must not be used in an open circuit, nor can they be connected to fuses

➤ DIMENSIONS OF OWCSTxxxT-Bxxx Current Sensor Transformer Pri. Built-In type

OW Series	A(mm)	B(mm)	C(mm)	D(mm)	E(mm)	F(mm)	G(mm)	H(mm)	I(mm)	J(mm)
OWCSTxxxT-Bxxx	17.5 Max	15.2Max	12.0Max	3.0+/- 0.5	15+/- 0.5	7.5+/- 0.5	12.5+/- 0.5	5.0+/- 0.5	0.64+/- 0.1	1.2+/- 0.1

Note: **OWCST xxxT - B xxx**

- ➔ Current Transformer Part number
- ➔ Type: B = Primary Built-In type
- ➔ Secondary winding turns
- ➔ OW current sensor transformer model

➤ **Electrical Characteristics of OWCSTxxxT-Bxxx Current Sensor Transformer Pri. Built-In type.**

No.	Item	Unit	Product Models				
			OWCST50T-B200	OWCST100T-B201	OWCST200T-B202	OWCST500T-B203	OWCST1000T-B204
1	Turns Ratio(Kr)	/	1:50	1:100	1:200	1:500	1:1000
2	Primary Current Max.	A(ac)	25	25	25	25	25
3	L _{sec} Min.	mH	4.7	18	76	470	1900
4	Test Condition	KHZ mV	10KHz 0.01V				
5	DCR _{sec.} Max.	Ω	0.5	2.0	4.5	16.0	50.0
5	Secondary Current Max.	mA	500	250	125	50	25
6	Volt μS Max.	/	175	350	700	1750	3500
7	Hi-Pot Pri to Sec.	V(ac)	4000V, 5mA 60"	4000V, 5mA 60"	4000V, 5mA 60"	4000V, 5mA 60"	4000V, 5mA 60"
8	Insulation Resistance	MΩ Min. 500Vac	500	500	500	500	500

Note:

- 1) This nominal termination resistance value will yield approximately 1.0V of output for each amp of current in a single turn sense line. The output Voltage/Ampere of these devices can be increased or decreased linearly over a restricted temperature range by adjusting the terminating resistance.
- 2) $V_{-us} = R_t \times I_{sec.} \times (1/2F)$
 --R_t(ohms) = Recommend Terminating Resistance
 --I_{sec.} = Secondary Current
 --F = Frequency
- 3) Please contact sales if your requirement is beyond the list by sales@owolff.com



➤ **Recommend Wave Soldering Condition of OWCSTxxxT-Bxxx Current Sensor Transformer**

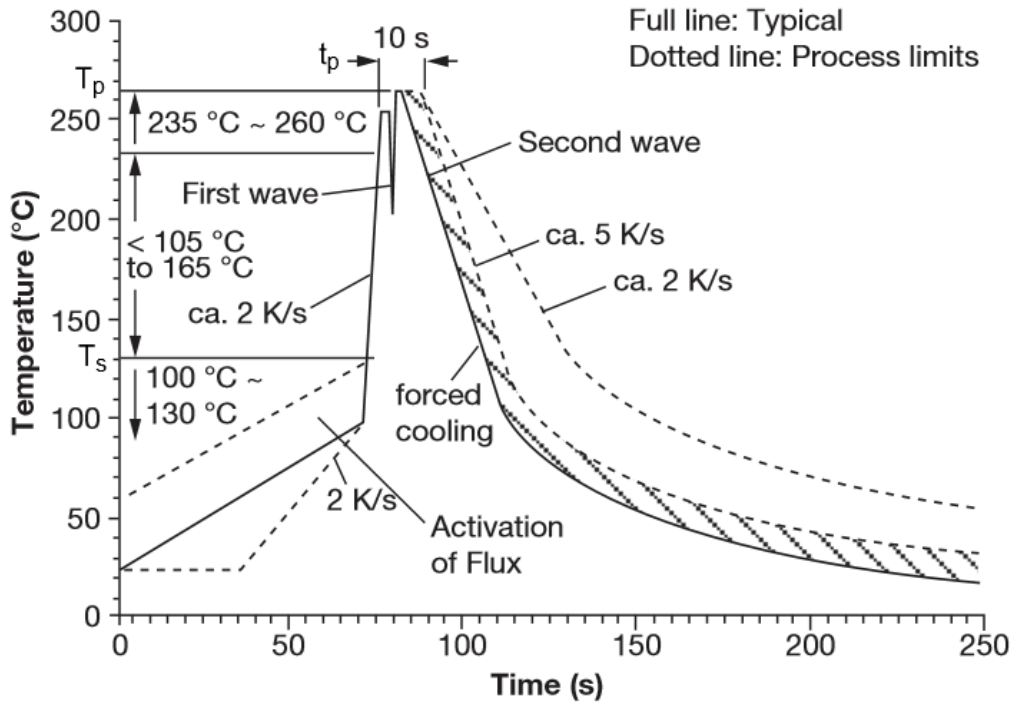

Profile Feature	Pb-free assembly
Average ramp-up rate	~ 200 °C/s
Heating rate during preheat	typical 1-2, max 4 °C/s 1-2
Final preheat temperature T_s	~ 130 °C
Peak temperature T_p	260 °C
Time within peak temperature t_p	10 s
Ramp-down rate	5 °C/s maximum

Notice:

- Refer to IPC A-610
- Above mentioned information should serve as recommendation only. Other parameters may also affect soldering results, so these profiles do not guarantee absolute success.
- Soldering profile should be determined by the manufacturer of the solder paste, providing there is no contradiction with the recommendations in this document.
- Strong forces which may affect the coplanarity of the components' electrical connection with the PCB (i.e. pins), can damage the part.
- Washing during the production to clean the customer application may damage or change the characteristics of the wire insulation, marking or plating. Washing may have a negative effect on the long-term functionality of the product. Customer need to be own evaluation risk.
- We do not recommend using brush PCBA during the cleaning process after soldering.
- If the product is potted in the customer applications, the potting material maybe shrink or expand after hardening, and lead to the part's electrical characteristics change or core crack, customer need to own evaluation the potting risk.



➤ **Packaging Detail of OWCSTxxxT-Bxxx Current Sensor Transformer**

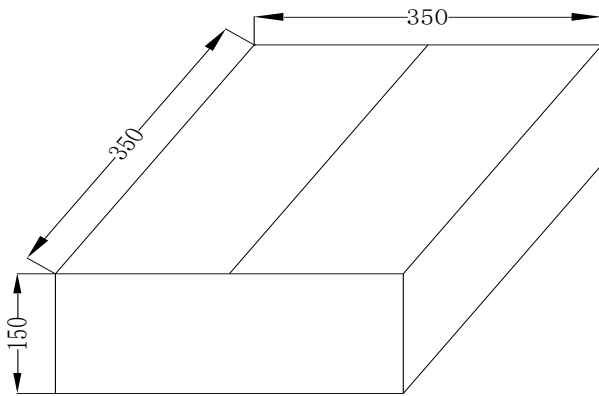
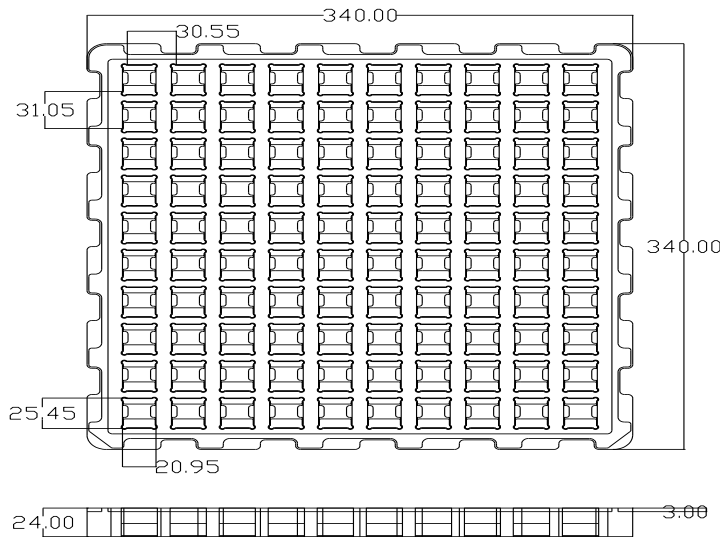

Item	Description
Bulk Packing	Paper box
Tray material	Degradable Plastic
Box Size	350x350x150
Tray size	340x340x20
Qty /Full tray	TBDpcs
Qty/Full Box	TBDpcs
Unit Weight	30g
Gross Weight	5.0Kg

Notice:

- A storage of OW products for longer than 12months is not recommended, the terminals may suffer degradation during storing, then the resulting in bad soldering performance. Customer need to be pre-evaluated the solderability before using over 12months inventory.
- Do not expose the component to direct sunlight, or to high humidity ambient.
- The storage conditions in the original packaging are defined according to EN61670-2, 12months shelf life Max. is in original packaging.
- It has to be clearly pointed out that the possibility of a malfunction of electronic components or failure before the end of the usual lifetime .cannot be completely eliminated in the current state of the art, even if the products are operated within the range of the specifications.
- The temperature rise of the component must be taken into consideration. The operating temperature is comprised of ambient temperature and temperature rise of the components .The operating temperature of the component shall not exceed the maximum temperature specified.
- Please handle it carefully because it is a fragile component. Please re-test and evaluate it again if the component is dropped to the floor.



➤ Caution and Notice

- Above mentioned information should serve as recommendation only. Other parameters may also affect soldering results, so these profiles do not guarantee absolute success.
- Soldering profile should be determined by the manufacturer of the solder paste, providing there is no contradiction with the recommendations in this document.
- Strong forces which may affect the coplanarity of the components' electrical connection with the PCB (i.e. pins), can damage the part.
- Washing during the production to clean the customer application may damage or change the characteristics of the wire insulation, marking or plating. Washing may have a negative effect on the long-term functionality of the product. Customer need to be own evaluation risk.
- We do not recommend using brush PCBA during the cleaning process after soldering.
- If the product is potted in the customer applications, the potting material maybe shrink or expand after hardening, and lead to the part's electrical characteristics change or core crack, customer need to own evaluation the potting risk.
- A stroage of OW products for longer than 12months is not recommended, the terminals may suffer degradation during storing, then the resulting in bad soldering performacne. Customer need to be pre-evaluated the solderability before using over 12months inventory.
- Do not expose the compoent to direct sunlight, or to high humidity ambinet.
- The stroage conditions is in the original packaging are defined according to EN61670-2, 12months shelf life Max. is in original packaging.
- It has to be clearly pointed out that the possibility of a malfunction of electronic components or failure before the end of the usual lifetime .cannot be completely eliminated in the current state of the art, even if the products are operated within the range of the specifications.
- The temperature rise of the component must be taken into consideration. The operating temperature is comprised of ambient temperature and temperature rise of the components .The operating temperature of the component shall not exceed the maximum temperature specified.
- Please hand it carefully because it is fragile component. Please re-test and evaluate it again if the component dropped to floor.

